

Section IV – Overhead Installation

NOTE: Depending on the vehicle, permanent modifications to the vehicle may be necessary to allow the installation of the Quantum Series Overhead and its related hardware. Professional installation is strongly recommended.

1. Align the mounting bracket to the desired mounting location, ensuring that the mounting holes line up with the vehicle's roof cross member. Verify that the mounting hardware (the included sheet metal screws, or otherwise) will not pierce the outer skin of the vehicle once the bracket is mounted. Carefully secure the bracket to the vehicle's roof cross member, making sure not to pinch the previously routed cables.

NOTE: If a ThinDVD is being installed at the same time, proceed to #4.

2. To install the optional ThinDVD player, carefully route the dome light wiring and the main system cable through the opening in the ThinDVD player. Loosely fasten the ThinDVD player to the mounting bracket with the supplied machine screws.
3. Before completely tightening down the ThinDVD player make sure to push all the excess cable back into the headliner leaving about six inches available. Tighten down the ThinDVD mounting screws making sure not to overtighten and distort the shape of the ThinDVD player.
4. Connect the dome light wiring harness, main system cable, modulator cable, and the ThinDVD din cable (if applicable) to the Quantum Series Overhead Monitor.
5. Carefully raise the Quantum Series Overhead into place, making sure not to pinch any of the system cables.
6. Mount the Quantum Series Overhead Monitor to the mounting bracket with the supplied machine screws. Do not overtighten!

Section V – Connecting System Power.

Plug the included in-line power filter to the main system cable and connect the power leads to 12V+ and 12V ground. The wires are color coded as follows:

Red = 12+VDC Constant Power

Yellow = 12+VDC Switched Power

Black = Ground

VIZUALOGIC
A Division of TMI Products, Inc.

Copyright © 2005 TMI Products, Inc.
All Rights Reserved

1493 Bentley Drive • Corona, CA 92879 • 951-272-1996 • 800-624-7960 • Fax 951-272-1584
www.vizualogic.com

99-7102-100 1/05

VIZUALOGIC®



Quantum™ Series
**OVERHEAD VIDEO SYSTEM
with ThinDVD CAPABILITY**

Installation Manual

System Components

The Vizualogic® Quantum™ Series Overhead Video System is available in 7" and 10.2" as well as with or without the optional ThinDVD player.

- Unified remote control. Controls monitor functions, ThinDVD functions and A/V source input selection.
- Integrated wireless FM transmitter.
- Depending on the installation, additional wiring and hardware may be required.

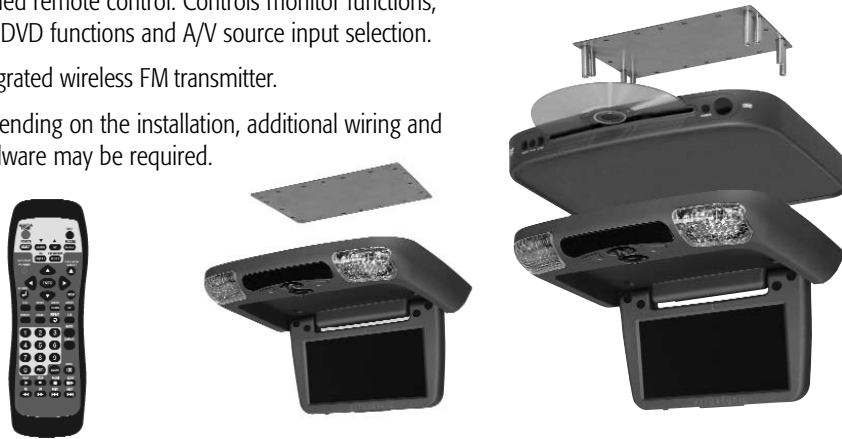

Overhead Installation

Section I – Vehicle Preparation

NOTE: The Quantum Series Overhead Monitor requires adequate roof support for a solid, trouble-free installation. Typically the Quantum Series Overhead will replace the domelight in the vehicle's headliner. Before attempting the installation, remove the vehicle's domelight and verify that there is sufficient clearance above the headliner and sufficient support from a roof beam available. Ensure that the placement of the Quantum Series Overhead Monitor does not interfere with or prevent the use of any overhead climate controls. If the optimal location on the vehicle's headliner is contoured, an optional Trim Ring will need to be modified and used.

Section II – Cable and Harness Routing

1. Starting at the headliner, route the main system cable down to the desired location in the vehicle. Repeat for the wireless FM transmitter cable. NOTE: The cables are directional, ensure that the marked ends have been observed and the cables are routed properly. Leave enough slack available in the headliner to facilitate connections to the Quantum Series Overhead.
2. Using electrical tape or wire-ties secure the cables in the vehicle so that they will not interfere with any vehicle functions, (i.e. Sunroof, Seatbelts, Airbags) and possibly cause squeaks or rattles.
3. Route the main system cable to the desired location in the vehicle and connect the 4 pin molex connector to the supplied noise filter. If necessary connect the RCA input and output cables to desired devices such as an external DVD player or game system.
4. Route the wireless FM transmitter cable to the desired location in the vehicle and connect the

wireless FM transmitter. Secure the FM transmitter to the vehicle and fully extend the transmitting antenna.

Section III – Dome Light Wiring

The Quantum Series Overhead has integrated dome lights that require three connections to the vehicle's dome light wiring. There are two common types of dome light circuits in today's vehicles, positive or negative switched. To determine which type of dome light circuit is present in the vehicle you must first locate the wiring at the dome light. Most dome lights use three wires: a constant, a switched, and a ground (some vehicles ground the dome light through a mounting screw). With a digital multi-meter (DMM) test the dome light wiring while opening and closing the doors. On a positive switched system the switched wire will rest at ground or show an open circuit. When a door is opened the wire will switch from it's present state to +12VDC. On a negative switched system, the switched wire will rest at +12VDC or show an open circuit. When a door is opened the wire will switch from it's present state to ground.

For **POSITIVE SWITCHED** Systems connect the BLUE wire to the vehicle's dome light switched wire. Then connect the RED wire to a fused constant +12VDC source and the BLACK wire to a good ground.

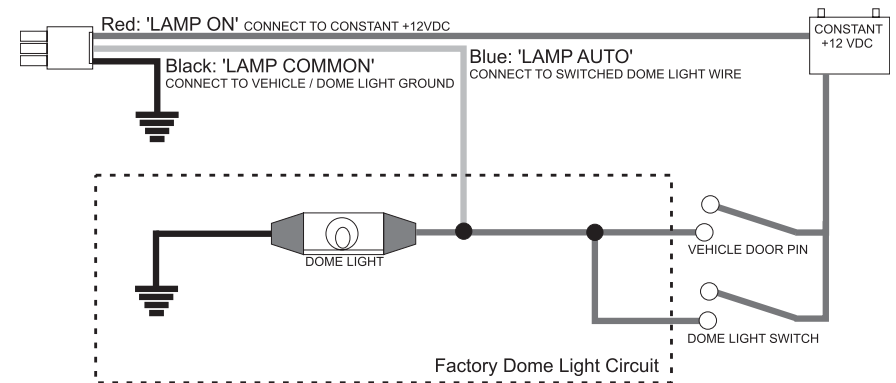

For **NEGATIVE SWITCHED** Systems connect the BLUE wire to the vehicle's dome light switched wire. Then connect the BLACK wire to a fused constant +12VDC source and the RED wire to a good ground.

